

BANI SILITRON

CATALOGO 2024

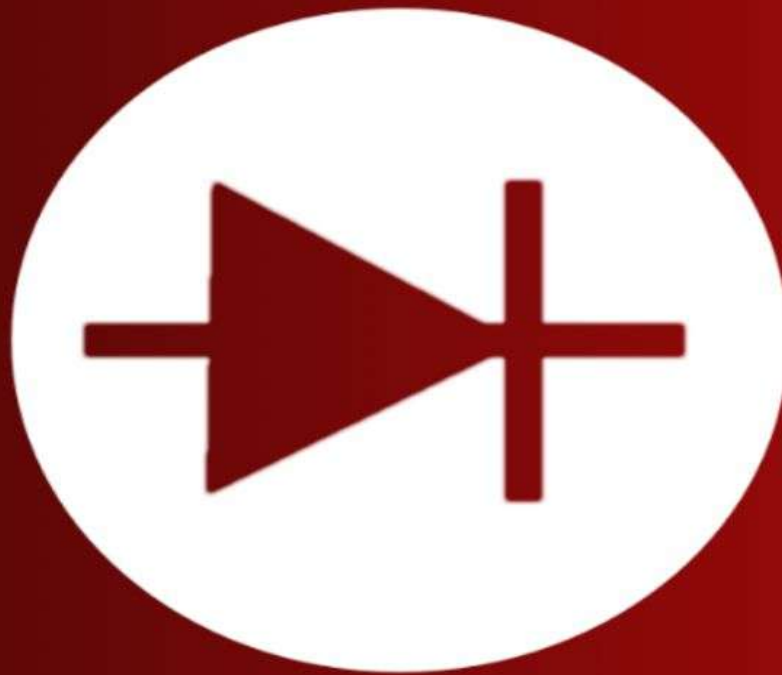

PLACAS RECTIFICADORAS

REGULADORES DEVOLTAJE. SOLENOIDES DE PARE. DIODOS

VOLTIMETROS



BT 12/24



ROJO

BT 12/24



VERDE

BT 12/24



AZUL

TESTER PARA BATERIA DE 12 A 28V

TESTER



DT-830 B



- V
- A
- RESISTENCIA
- DIODO
- TEMPERATURA
- HFE
- S/SONDA

DT-838



- V
- A
- HFE
- TEMPERATURA
- BUZZER
- DIODO
- C/SONDA

DT-850 L



- V
- A
- RESISTENCIA
- DIODO
- HFE
- BUZZER
- S/SONDA

AA - 3



Reemplazo Argelite. Aplicación: Placa Positiva, 35 - 40 - 42A, Ford, Renault, GM, Fiat, etc.

AA - 8



Reemplazo Argelite. Aplicación: Placa Positiva, Alternador 4 pulgadas, Citroen, Fiat, Renault.

AA - 9



Reemplazo Argelite. Aplicación: Placa Positiva, 28 - 38 - 42A, Renault, Citroen, Fiat Peugeot, Dodge.

AA - 10



Reemplazo Argelite. Aplicación: Placa Negativa, 28 - 38 - 42A, Renault, Citroen, Fiat Peugeot, Dodge.

AA - 35



Aplicacion: circuito Auxiliar, Renault.

AA - 47



Aplicacion: Placa Positiva
Renault 9,11,18 70A

AA - 49



Aplicacion: Placa Negativa
Renault 9,11,18 70A

AB - 96

N:PRB 080277



REEMPLAZA BOSCH 114 MM 127.011.113/115 - 127.32.081/103
ECORT GHIA 1.8/ESCORT XR 31.8 GOL, SENDA, PASSAT, POINTER

AB - 97

N:PRB 320506



REEMPLAZA BOSCH 1.127.320.506A AUDI SERIE 4000, VW DIESEL,
BORA, Dasher, QUANTUM, RABBIT, SCIROCCO, SALIDA W, 114 MM

AB - 98



REEMPLAZA BOSCH SALIDA W
6 DIODOS C/TRIO 114 MM

AB - 101

N:PRB 320961



REEMPLAZA BOSCH 1.127.320.920 / 1.127.320.961
CASE TRACTORES, MB, SCANIA, VOLVO 125 MM

AB - 115

N:PRB 320547



REEMPLAZA BOSCH 140 AMP - ALTERNADOR WAPSA MAFERSA,
VW CAMIONES, VOLVO, VALMET TRACTORES SCANIA, MERCEDES BENZ

AB - 125

N:PRB 320955



REEMPLAZA BOSCH 1.127.320.928/946/956/969/989 1.127.320.602/924/951
MERCEDES BENZ, SCANIA VOLVO DAF, KHD/MAN 125 MM

AB - 126

N:PRB 320968



OH 120 mm 11 DIODOS.

AB - 127

N:PRB 320977



OH 120 mm 17 DIODOS/
TORNILLO AUXILIAR DESPLAZADO 3mm

AB - 129



N:PRB 320753

Reemplaza: Bosh 1127320753 | 1127320750. Aplicación: 80A MB Omnibus OF 915, 1417 equipamiento con OM 904 LA 4 cil. Camiones Mercedes

AB - 130



N:PRB 320565

Reemplaza: Bosch 1.127.320.565/681 | 705/710/722/723/732/ | 737/739. Aplicación: 115A Alfa Romeo/ Audi/ BMW Ford Galaxy y Versalles c/A.A. (AP) desde 03/92/ MB/ Porsche Saab/ VW Santana/ Volvo 120 mm

AB - 131



N:PRB 320701

Reemplaza: Bosch 1127320701. Aplicación: 115A VW Alternadores Bosch serie 469 IR/EF 115A VW Salida W 120 mm

AB - 132



N:PRB 319667

FOO:319540

AB - 133



N:PRB 319560

Reemplaza: Bosch 1127319623 1127320882. Aplicación: 90 A BMW M3, 325i,525i Ford, Volkswagen 6 diodos c/trio 112 mm

AB - 134



N:PRB 319510

Reemplaza: Bosch 1127319510 1127320844 1127319593 1127320864 1127319730 1127320807. Aplicación: Volkswagen, Ford, Mercedes BMW 6 diodos c/trio 112 mm

AB - 135



N:PRB 319694

Reemplaza: Bosch 1127319694. Aplicación: Lancia, Peugeot, Citroen 6 diodos c/trio 112 mm

AB - 224



N:PRB 133200

REEMPLAZA BOSCH PORSCHE BOXTER, 911, OPEL ASTRA, ZAFIRA, CORSA, FORD MONDEO, FORD TRANSIT 2.4L DIESEL, TOYOTA, NISSAN, MERCEDEZ BEZ 120 MMF OOM 133 200, F OOM 123 202, F O03 123 233, F OOM 123 238

AB - 225

N:PRB 133201



Reemplaza: Bosch F 00M 133 201/205 F 00M 133 218 F 00M 133 228 F 00M 133 241 F 00M 133 246/47 F 00M 123 215. Aplicación: AUDI A4, Quattro, Avant, Passat 1.6V, 1.8, Passat Variant VW, Fiat, Ford

AB - 226

N:PRB 133207



Reemplaza: Bosch F 00M 113 207. Aplicación: Fiat Siena 8 diodos 120 mm

AB - 227

N:PRB 133224



REEMPLAZA BOSCH MERCEDEZ BENZ 24 VLT

AB - 228

N:PRB 123215



REEMPLAZA BOSCH F00M133223, 6 DIODOS, 24 VOLT CAMIONES RENAULT, VOLVO

AB - 229

N:PRB 133243



AB - 230

N:F00BL0600



FOOLB 0600

AB - 231

PBO 123310



FOOM 123310

AB - 232

FOO 0123238



FOOM 123238 TOYOTA

AB - 233

8 DIODOS/120mm



APLICACION:MB Fiat Volvo

AB - 234

8 DIODOS/120mm



APLICACION: MB Fiat,volvo

AB - 235

PBO 320152



APLICACION:J.DEERE
DIAMETRO:91,5

AB - 236



6 DIODOS SIN SALIDA TRIDIODOS
APLICACION: RENAULT,GM

AB - 237

PBO 319690



APLICACION: MB,VOLVO,BMW
DIAMETRO:131

AB - 238

PBO 319667



APLICACION:MB,VOLVO,BMW
DIAMETRO: 131

AB - 239

PBO 319570



Diametro Ford KA

AB - 301

N:1127011139



REEMPLAZA BOSCH 1.127.011.139 1.127.320.372 1.127.320.580 1.127.320.652
Aplic: Ford Cargo van 45-55A 114mm

AB - 302

N:PRB 011131



Reemplaza: Bosch 1.127.011.131 F.000.LD1.012 Aplic: 70A Ford pick up F1000 HSD (Maxim High Speed), F1000T (MWM-4.10T) (10.95) 9 120 080 230 K1 70 14/MB Sprinter 310D c/m OM-014A s/A.A. (09.96) 9 120 080 212 K1 70 14, Volvo Diesel, Linea Renault 114mm

AB - 303

N:PRB 080275



Reempla: Bosch 1.127.011.117/125 9.122.080.275/9.128.040.282 1.127.320.148/50 1.127.320.383/85 1.127.320.622/24 Aplic:75A Fiat , Chevrolet ,Audi ,BMW Opel, Saab 114mm

AB - 304

N:PRB 320664



Reemplaza: Bosch 1.127.320.664/66
Aplic: Foed, VW salida W 114mm

AB - 305

N:PRB 320914



Reemplaza: Bosch 1.127.320.601 1.127.320.661/62 1.127.320.691
Aplic: Audi, Saab, Scania, VolksWagen 114mm

AB - 306

N:PRB 320651



Reemplaza: Bosch 1.127.320.651 1.127.320.677
Aplic: GM, OPEL 65A 114mm

AB - 307

N:PRB 320664



Reemplaza: Bosch 1.127.320.914
Aplic: GM,OPEL Salida W 65A 114mm

AB - 308

N:9121147302



Reemplaza: Bosch
Aplic: GM, OPEL 50-70A 114mm

AB - 309

N:PRB 320651



Reemplaza: Bosch 1.127.320.651 1.127.320.677
Aplic: Linea General Motors 114mm

AB - 310



N:PRB 011131

Reemplaza: Bosch 9.128.040.275
Aplic: Industrial 114mm

AB- 311



N:PRB 320366

Reemplaza: Bosch 1.127.011.098 1.127.011.101 1127320344/63 1.127.320.545/46 1.127.320.366/67
Aplic: DAF, Saab Scania M.Benz Cam.1113/1313/1316/1513/1516/2013/2213/2216 (OM 352)
c/dir.Hidr Chasis OF-OH1113/1313/18 95A 11Amm

AB - 312



N:PRB 320541

REEMPLAZA BOSCH 114 MM 95A MERCEDES BENZ CAMIONES
1.127.011.095/96/97 1.127.320.331 - 1.127.320.364/65/68
1.127.320.375/98

AB - 313



N:PRB 320909

Reemplaza: Bosch 9.122.080.506 Aplic: JI Case Trac.,
Komatsu Tractores M.Benz Camiones Toyota 35A 114mm

AB - 314



N:PRB 080676

Reemplaza: Bosch 9.122.080.676
Aplic:Ford Escort 2.0i Xr3 95A 114mm

AB - 315



N:PRB 320692

Reemplaza: Bosch 1.127.320.692 Aplic: Iveco,JI Case,
John Deere, KHD, New Holland Ford Orion 114mm

AB - 316



N:9122080336

Reemplaza: Bosch 9.122.080.336 M.F Tractor 3640 Camiones/Microomnibus,
motores estacionarios, industriales , generadores y maritimos OM 35A 114mm

AB - 317



N:PRB 320909

Reemplaza: Bosch 1.127.320.909 9.127.041.132 9.127.041.133
Aplic:Mercedes Benz Camiones 35A 114mm

AB - 318



N:9128040953

Reemplaza: Bosch 9.128.040.953 / 9.128.040J
 Aplic: Ford 75-90A 114mm

AB - 319



N:PRB 080232

REEMPLAZA BOSCH F 010 LD1 067 114 MM
 RENAULT, SPRINTER, SILVERADO, RANGER 65 AMP

AB - 320



N:PRB 080923

Reemplaza: Bosch Aplic: Renault CLIO 19
 70-90A 114mm

AB - 321



Reemplaza Bosch
 Aplic. Renault 70-90 Amp

AB - 322



N:9123080129

Reemplaza: Bosch 9.123.080.129
 Aplic: VW Gol 1.0.MI VW GOLF 65A 112mm

AB - 323



N:PRB 080089

REEMPLAZA BOSCH 112 MM 9.123.080.089 FORD ESCORT, ORION
 VW GACEL, GOL, SENDA, POINTER VW GOL 1000, CORSA WIND 1000



ADR-150 N:PDE 2744 102mm

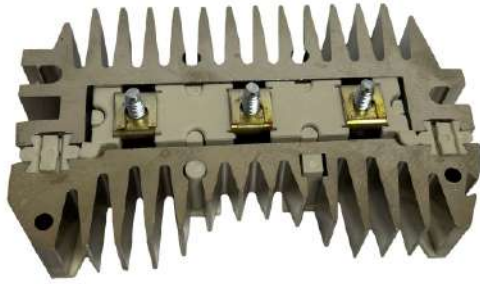

6 DELCO REMY 100-200

ADR-85 N:PDE 472311 64mm



APLICACION: Ford

ADR-151 N:PDE 3824 95mm



APLICACION: GM

k-262



KIT COMPLETO GM/Dadwo

ADR-153 N:PDE 10497503 118mm



DELCO ADR 230

ADR-1297 N:PDE 751257



APLICACION: Chevrolet Cobal T, Cruze

ADR-154 84mm

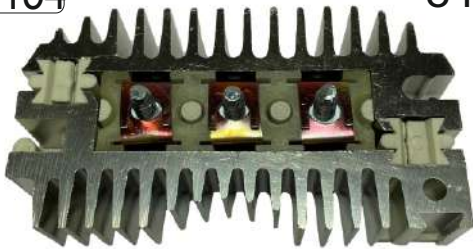

APLICACION: GM 80

K-260



KIT COMPLETO. APLICACION: Chevrolet Cobal T, Cruze

ADR-176 N:PDE 3992

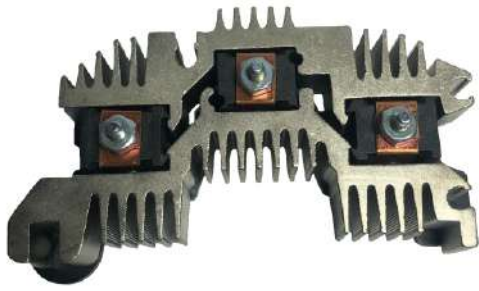

APLICACION:MB

ADR-9411N

N:PDE 19020601



APLICACION:Nautico

ADR-7000 N:PDAE 7000



APLICACION: Daewo.Delco Core 6 Diodos con placa auxiliar

ADR-658/100 N:PDE 89658



APLICACION:GM Corsa 1.6

ADR-5034/103



APLICACION:GM Astra, Omega, Vectra, Corsa Wind

ADR-5758 N:PDE 75758



APLICACION:GM Corsa c/aa Omega; Vectra 2.2; Honda

ADR-1753 N:PDEFZ 1753



APLICACION:Chery Face, QQ

ADR-6871 N:PDE 201753



APLICACION:Daewoo

AD - 44



Reemplaza Ducellier 581 162, 690 973.
Aplicación: Citroen, 17.5 mm.

AD - 44B



Reemplaza Ducellier.
Aplicación: Citroen, 17.5 mm, C /Trio.

AD - 45



Reemplaza Ducellier 581 163, 690 974, 691 463.
Aplicación: Renault, 24 mm.

AD - 45B

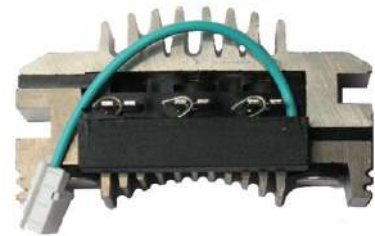

Reemplaza Ducellier.
Aplicación: Renault, 24 mm, C /Trio.

AG - 1



Reemplaza Garef 4802400.
Aplicación: Placa Positiva. Todo alternador Garef

AG - 2



Reemplaza: Garef.
Aplicacion: Placa Positiva 75A Todo alternador Garef

AG - 26

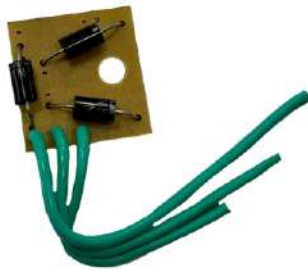

Aplicacion: Circuito Auxiliar
sin tornillo. Todo alternador Garef

AG - 32



REEMPLAZA GAREF 4880500- 4880600
CIRCUITO AUXILIAR 38-50 A TODO ALTERNADOR GAREF

AG - 76



Aplicacion: Conjunto Rectificador
Todo alternador Garef



AH-94

110 mm



APLICACIONES: Hitachi isuzu PHI 13205

AH-113

110 mm



APLICACIONES: Massey ferguson L 1353320

AH-114

118 mm



APLICACIONES: Nissan 23230/1605

AH-121

100 mm



APLICACIONES: Marssey ferguson, Yanmar, Nissan

AH-122



APLICACIONES: Nissan PHI 170748

AH-123



APLICACIONES: Nissan PHI 709B

AH-401

155 mm



APLICACIONES: Corsa gasolero 1,7.
PHI 23203

AH-409

127 mm



APLICACIONES: Hitachi Meriva
8 Diodos s/trio, tornillo M8. PHI 769



AH-441



PHI 23203
U3319

APLICACION: Corsa, Vectra Diesel, Opel, GM

AH-442



PHI 769
U170509

APLICACION: Vectra Corsa-Hitachi

AH-445



PHI 027011

Aplicacion: Hyundai, H1

AH-444



PHI 2320
U23215

APLICACION: Nissan Centra

AH-447



PHI 711B
U190744

Aplicacion: Honda Isuzu

AH-446



PHI 02711
U27011

Aplicacion: Hyundai, H1



AHI - 420

K 1174



8 DIODOS C/TRIO VW GOL 1.6 1.8/POLO D

AHI - 421

K 1153



8 DIODOS C/TRIO VW GOL/SAVEIRO/CAMIONES/PARATI

AHI- 422

K 1201



6 DIODOS C/TRIO VW SAVEIRO III Y 2G/GOL/PARATI

AHI - 423

K 1202



6 DIODOS C/TRIO VW GOL/SAVEIRO/PARATI 2G EA 111

AHI - 424

M5 LARGO

K 1215



8 DIODOS C/TRIO FIAT/VW/J.DEERE/VW GOL POLO

AHI - 425

K 1374



8 DIODOS C/PUENTE RENAULT 19 21/CLIO FULL

AHI - 426

K 1375



6 DIODOS C/PUENTE RENAULT EXPRESS DIESEL

AHI - 427

M5 LARGO

K 1269



6 DIODOS C/TRIO BALMAR



AHI - 428

M5 CORTO

K 1441



8 DIODOS C/TRIO FORD RANGER NAFTA 2.3

AHI - 429

M5 CORTO

K 1402



6 DIODOS C/TRIO FORD MOTOR 1.6

AHI- 430

M5 CORTO

K 1503



6 DIODOS C/TRIO CUMMINS/PAUNY/VASALI

AHI - 431

M5 LARGO

K 1509



6 DIODOS C/TRIO CHEVROLET S10/UNIVERSAL

AHI - 432

M5 LARGO

K 1216



6 DIODOS C/TRIO CORSA NAFTA/VW GOL/SAVEIRO/SENDA

AHI - 433

M5 LARGO

35214512



8 DIODOS C/TRIO PEUGEOT 306/405

AHI - 434

K 1596



8 DIODOS C/PUENTE LIFAN

AHI - 435

M5 LARGO

K 1377



8 DIODOS C/TRIO UNIVERSAL 1V 110A (SIN POLEA)

AHI - 436

M5 LARGO

K 1312



8 DIODOS C/TRIO CORSA/VW POLO 1.6 1.8/GOL/SAVEIRO

AHI - 437

K 1376



8 DIODOS C/PUENTE RENAULT 19/CLIO FULL DIESEL Y NAFTA

AHI - 438

RI - 1213
AHI - 412



Aplicacion: Balmar, Peugeot. 8 Diodos.

AHI - 443

RI - 1444
AHI - 404



Universal 14V/110A (Sin polea)

AHI - 411



Tornillo M6. 8Diodos.

AHI - 412



Tornillo M8, 8Diodos C/TRIO.

AHI - 413



Tornillo M8, 6Diodos C/TRIO.

AHI - 402

K 01507



Reemplaza: Hitachi-Indiel k01507 Aplic:Dimex/ J.Deere Peugeot.
TORNILLO M6, 6 DIODOS CON PUENTE

AHI - 403

K 01208



REEMPLAZA HITACHI 35214571 K 01208- 6 DIODOS C/TRIO - TORNILLO M8
CORSA NAFTA 1.0-1.4-1.6S/A.A.(P.SIMPLE) VW GOL, C/M AP 827 S/A.A.,
SEDA DIESEL FULL/ P.MULTI V) C/DESEMP. GOL III / SAVEIRO

AHI - 404

K 01313



APLICACION:Fiat Palio y Siena D.GM Corsa Nafta 1.6 c/AA
TORNILLO M8, 8 DIODOS C/TRIO

AHI - 405

K 01381



APLICACION:Renault Express Diesel Polea Multi V6 Diodos
c/puente Tornillo M6

AHI - 406

K 01382



APLICACION:Renault 19 c/m 1.7,1.8,Clio Full Diesel
TORNILLO M6, 8 DIODOS C/PUENTE

AHI - 407

K 01378



TORNILLO M6 , 8DIODOS C/PUENTE

AHI - 408

K 01442



TORNILLO M8, 8 DIODOS CON PUENTE

AI-4



APLICACION: Deutz Cosechadora (P.doble)
Fiat Duna/Fiorino/Spazio

AI-5



APLICACION: Deutz Cosechadora (P.doble) Fiat
Duna/Fiorino/Spazio 1147 Ford Falcon/F100

AI-11



APLICACION: Fiat Regatta, Duna, Uno
Ford Falcon

AI-12



APLICACION: Fiat Regatta, Duna, Uno.

AI-13



APLICACION: Ford Escort, Galaxy, Guaraja (Brasil)
C/M Audi 1.6, 1.8 y 2.0

AI-14



APLICACION: Ford Escort, Galaxy
C/AA C/M Audi 1.6, 1.8 y 2.0

AI-21



APLICACION: Fiat Regatta 100 1.6-2.0, Duna
Uno Ford Falcon.

AI-22



APLICACION: MB Linea vieja, Ford Escort/
Saveiro C/M

AI - 23



Aplicacion: Positiva Ford Sierra 2.3c/AA
MB,Scania

AI - 24



Aplicacion:Negativa Ford Sierra 2.3 c/AA
MB, Scania

AI - 25



Aplicacion:Auxiliar dos cables
Alternador c/luz piloto 28,32,38,42A

AI - 27



35212792

Aplicacion:Auxiliar
Alternador c/luz piloto 32,55,70,90A

AI - 31B



35213811

Aplicacion:Auxiliar
Alternador 70A Ccon cable salida trio

AI - 31

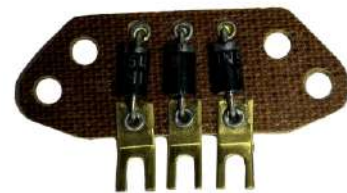

35213293

Aplicacion:Fiat,ford,J.Deere,
MB,Peugeot,Scania,VW Universal

AI - 36



Aplicacion:Auxiliar c/puente
renault

AI - 38



Aplicacion: fiat duna, Fiorino, Spazio

AI - 38D



Aplicacion: Peugeot 504/505s/A.A.
Nafta y Diesel

AI - 38R

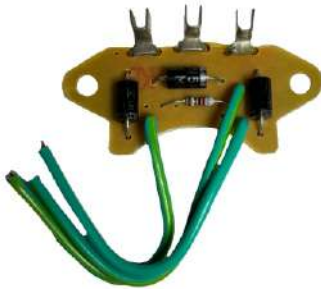

Aplicacion: Renault 12/18c/m 1.4 y 1.6
Traffi c c/m 1.4

AI 41/42



Aplicacion: Ford Motor Borgward/Taurus c/AA
12V 60A

AI - 54



Aplicacion: Ford F100/F4000/F7000
Motores MWM(Brasil)

AI - 59

K03639



APLICACION: Perkins

AI-60

U2529-SPA



APLICACIONES: S/placa auxiliar,Peuge,Ford, Fiar,Renault

AI-61

K 02529



APLICACIONES: Indiel 35212529

AI - 61B

K04506



APLICACION: J.Deere

AI-62



APLICACIONES: Indiel 35213136

AI-63



APLICACIONES:C/Placa auxiliar s/tridiodos

AI-64

N:PRI 213437



APLICACIONES:Indiel 35213427

AI - 65

K03676
31213646



APLICACION: MB Doble polea

AI - 66

K03672



APLICACION: Renault 9,11,18, Traffic 1.4 y 1.6

AI - 67

N:PRI 213682 K03682



APLICACION: Ford Escort, Galaxy/Guaraja

AI - 68

N:PRI 213274



APLICACION: Indiel 35213274

AI - 69

K 03274



Aplicacion: MB Polea doble 55,60 A

AI - 70



Aplicacion: MB Polea doble 75A

AI - 71

K03563



APLICACION: Cummins, MB Scania Ford 14000 c/m

AI - 72

K03631



APLICACION: Agrale Borgward Ford motor 2.3 c/AA

AI - 73



Aplicacion: Ford Escort c/AA
c/m Audi 1.6, 1.8 y 2.0 VW 75A

AI - 75

K 03252/K 03596



APLICACION: 90A Indiel 3521392

AI - 108

N:PRI 213894



APLICACION:Indiel 35213894
motores MWM

AI-339A

N:PRI K03939

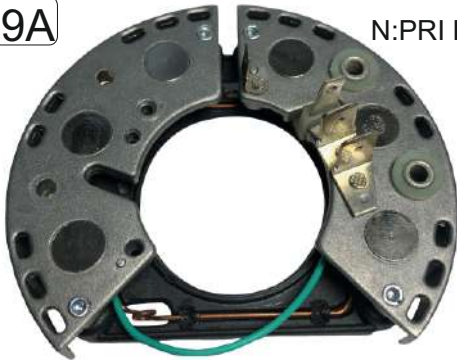

APLICACIONES:Ford Escort/Orion,M.BENZ

AI-339B

N:PRI K04039



APLICACIONES:GM Chevrolet,Pinck UP

AI-339C

N:PRI K04066



APLICACIONES:

AI-339D

N:PRI K04442



APLICACIONES: Ford Ranger/F100 GM S10-M.BENZ SPRINTER

AI-339E



APLICACIONES:Peugeot 504/505 full nafta y disel universal

AI-339F



APLICACIONES:Ford Ranger F100 GM S 10, MB SPRINTER



ALM-116

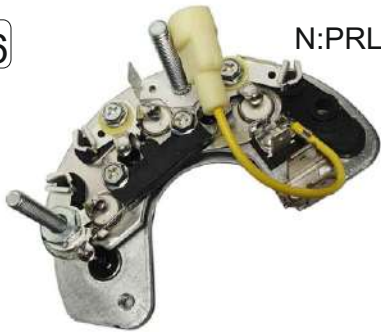

N:PRL UBB133

APLICACION: Massey Ferguson, Nissan, Rover
Ford Scord.

ALM-117



N:PRL UBB137

APLICACION: Ford Tractor, Fiesta
c/alternador Lucas.

ALM-118

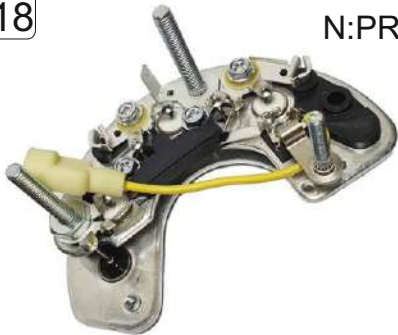

N:PRL UBB145

APLICACION: Ford Transit, Rover.

ALM-119



N:PRL UBB147

APLICACION: Ford Transit Industrial.

ALM-120



N:PRL UBB140

APLICACION: Ford, Nissan.

RLM - 148



KIT LUCAS MARELLI



ALM 117
RLM 148

AMM - 81

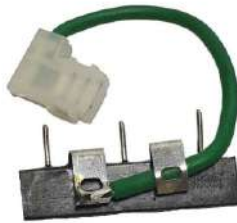

APLICACION: Circuito auxiliar/luz piloto/fiat/reault

AMM - 88 N:PRM 622001



APLICACION: Fiat temprá, Tipo 17,5 mm 55A

AMM - 89 N:PRM 621501

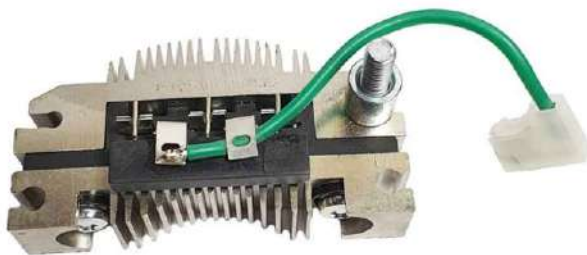

17,5 mm/55A

AMM - 90

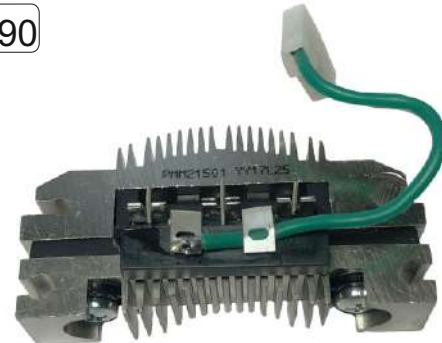

APLICACION: RENAULT,FIAT

AMM-91 N:PRM 022101



APLICACION: Renault, Fiat 17,5 mm 55A

AMM - 92



20 mm/55A

AMM - 93



20 mm/55A

AMM-501 N:PRM 1010



APLICACION: Fiat Palio, Tempra, Punto M8 +

AMM - 502

N:PRM 62370



APLICACION:Fiat Brava,Marea Land Rover, palio MB+

AMM - 503

N:PRM 623601



APLICACION:Fiat M8+

AMM - 504



APLICACION:Fiat Marea,Palio,Punto,Alfa Romeo M6+

AMM - 505

N:PRM 321679



APLICACION:Ford M6.

AMM - 506



APLICACION: Ford. M8

AM-900

REEMP. ROTOF:PMIT32570

75mm 8Diodos
Tornillo 5 derecho



APLICACION: Honda, Suzuki

AM-901

REEMP. RT:PMIT02675

65mm 6Diodos
Tornillo izquierdo



AM-902

REEMP. RF:PMIT02674

75mm 6Diodos
Tornillo 6 derecho



APLICACION: Peugeot

AMM-903

RF:PMIT 10057

100mm



APLICACION: Ford Transit

AM-904

REEMP. RT:PMIT02674

65mm 6diodos
Tornillo derecho



AMM-905

53mm



APLICACION: Subaru

AM-906

REEMP. RF:PMIT16770

65mm 6diodos



APLICACION: Honda. Mitsubishi,
Hyundai. Dogde

AMM-907

RF:PMIT 47770

85mm 6DIODOS



APLICACION: Mazda



AMM-908 RF: PMIT 13470 75mm 6Diodos
Tornillo 6 derecho



APLICACION:Nissan

AMM-909 RF:PMIT 45281 75mm 8 Diodos
Tornillo 6 derecho

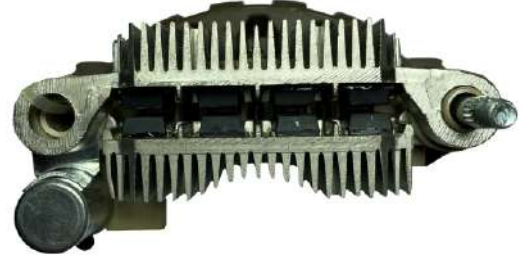

APLICACION: Honda

AMM-910 RF:PMIT 37870 75mm 6 Diodos
Tornillo 6 derecho



APLICACION: Honda Civic

AM-911 RF:PMIT45170 85mm

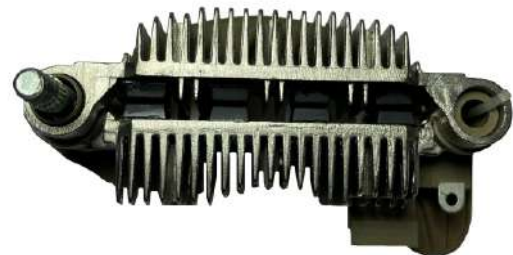

APLICACION: Infiniti(1994-1997)
Nissan-Europe(1996-2000)

AM-912 RT:PMIT1691 85mm 8Diodos



APLICACION: Mazda, Subaru

AM-913 RF:PMAN75292 90mm



APLICACION: Bobcat y Alternadores
Mando 90A IR/IF

AM-914 RF:PMIT8494 100mm



APLICACION: Veco Stralis

AM-915 100mm



APLICACION: Peugeot 8diodos c/puente
salida tornillo 6mm

AN - 6C



REEMPLAZA NASHVILLE 010100

AN - 7C



REEMPLAZA NASHVILLE 010100
PLACA POSITIVA - DIODOS CLAVADOS 55 - 70 A

AN - 46



REEMPLAZA NASHVILLE 014300
CIRCUITO AUXILIAR LUZ PILOTO
CUMMINS, M.BENZ, OMNIBUS EL DETALLE

AN - 48



CIRCUITO AUXILIAR LUZ PILOTO
MERCEDES BENZ CUMMINS

AN - 56



PLACA POSITIVA
100 - 130A

AN - 57



PLACA NEGATIVA
100 - 130A

AN - 74C



REEMPLAZA NASHVILLE -010050 DIODOS CLAVADOS
OMNIBUS EL DETALLE, CUMMINS, VW CAMION, M.BENZ SCANIA 55 - 70 A

AN - 74



REEMPLAZA NASHVILLE 010050 DIODOS SOLDADOS
OMNIBUS EL DETALLE, CUMMINS, VW CAMION, M.BENZ, SCANIA 55 - 70 AMP



AN - 95



Reemplaza: Nashville # 019130.
Aplicación: Mercedes Benz Cummins 100 - 130 A

AN - 102



Reemplaza: Nashville # 015610.
Aplicación: Uso General 100 - 130 A

AN - 109



Reemplaza: Nashville # 017162.
Aplicación: Placa Positiva 120 - 160 A

AN - 110



Reemplaza: Nashville # 017212.
Aplicación: Placa Negativa 120 - 160 A

AN - 111



Reemplaza: Nashville # 018930.
Aplicación: Auxiliar Luz Piloto 120 - 160 A

AN - 112



Reemplaza: Nashville # 017300 # 017310.
Aplicación: Buses Scania M. Benz Deutz Marco Polo
motor Scania 120 - 160 A

AND-166 100mm

N:PRN 804990



TOYOTA,HONDA,ISUZU

AND-174



TOYOTA ARGENTINA

AND-167 93mm

N:PRN 551590



ISUZU,TOYOTA

AND-163 103mm

N:PRN 804760



TOYOTA,COROLLA,CELICA

AND-168

N:PRN 001491



TOYOTA CELICA, COROLLA

AND-164 100mm

N:PRN 804850



DOGDE,CHYSLER

AND-169

N:PRN 1340



HONDA

AND-43 100mm

N:PRN 805300



HONDA,ISUZU,TOYOTA PICK UP



AND-170



FORD FOCUS TDCI

PNIP3511

K246



CONJUNTO COMPLETO A-170E Y REGULADOR

PNIP3511 U03010

AND-171



CHRYSLER, DOGDE, JEEP

PNIP0432

K247



CONJUNTO COMPLETO A-171E Y REGULADOR

PNIP0432 U00022

AND-172



HONDA, JEEP, LAND ROVER, RAM.

PNIP5891

K248



CONJUNTO COMPLETO A-172E Y REGULADOR

PNIP5891 U003020

AND-173



TOYOTA HILUX DESDE EL 2005

PNIP809220

K245



CONJUNTO COMPLETO A-173E Y REGULADOR

PNIP809220 U0150

AV-40A

N:PRV 101743



APLICACION:Renault,Volvo POSITIVO IZQ.85 AMP

AV-40B

N:PRV 103551



APLICACION:Renault POSITIVO IZQ.C/TRIO 85 AMP

AV-40C

N:PRV 104292



APLICACION:Citroen,Peugeot NEGATIVO IZQ.85 AMP

AV-40D

N:PRV 101713



APLICACION:Renault NEGATIVO IZQ.C/TRIO 85 AMP

AV-40

N:PRV 100157



APLICACION:Renault,Jeep,POSITIVO IZQ. 120 AMP

AV-40F



APLICACION:Renault POSITIVO IZQUIERDA C/TRIO

AV-40G



APLICACION:Renault POSITIVO IZQUIERDO 120 AMP

AV-40H



APLICACION:Renault,Volvo NEG IZQUIERDA C/TRIO 120AMP

AV-105



N:PRV 546048

VALEO 2545938/545937
 APLICACION: Renault,Citroen,Peugeot
 6 DIODOS CON TRIDIODO AUX.

AV-106



N:PRV 545941

VALEO 2545941/NF007
 APLICACION: Renault,Peugeot
 8 DIODOS CON TRIDIODO AUX.

AV-107



APLICACION: Renault
 8 DIODOS SIN TRIDIODO CON PUENTE

AV-801



N: PRV 593172

VALEO 593172
 APLICACION:Renault,Peugeot,Citroen
 6 DIODOS SIN TRIDIODO, SIN SALIDA CAPY DOBLE SALIDA REG

AV-802



N:PRV 593164

VALEO 593174
 APLICACION:Renault,Peugeot,Citroen
 8 DIODOS SIN TRIDIODO , SIN SALIDA CAP Y DOBLE SALIDA REG.

AV-803



N:PRV 596062

VALEO 546062
 APLICACION: Renault,Peugeot
 6 DIODOS CON TRIO Y DOBLE SALIDA REG

AV-804



VALEO 545941
 APLICACION:Renault,Peugeot
 8 DIODOS CON TRIO Y DOBLE SALIDA REG

AV-80



VALEO 501001
 APLICACION:Ford,MB,VW
 6 DIODOS CON TRI DIODO

AV-701



VALEO 593397
 APLICACION: RENAULT ESPACE/LAGUNA/MEGANE/
 SCENIC DIESEL

AV-702



VALEO 2650236
 APLICACION: CHEVROLET/GMC

AV-703



VALEO 593508
 APLICACION: CHEVROLET/ CORSA 1.8 MERIVA
 (SIN TRIDIODOS AUXILIARES)

AV-704



VALEO 493819
 APLICACION: CHEVROLET/ MERIVA/ ASTRA/ BLAZER/ S10
 (CON TRIDIODOS AUXILIARES)

AV-705



VALEO 619399
 APLICACION: PEUGEOT 206/ KIA PICANTO/ HYUNDAI
 (SIN TRIDIODOS AUXILIARES)

AV-706



VALEO 004030/593529
 APLICACION: PEUGEOT 206, 207
 (CON TRIDIODOS AUXILIARES)

AV-707



VALEO 265517
 APLICACION: KIA PICANTO/ HYUNDAI
 (CON TRIDIODOS AUXILIARES)

AV-708



VALEO 265518
 APLICACION: KIA PICANTO/ PEUGEOT
 (SIN TRIDIODOS AUXILIARES)



AV - 709

PRV: 593508



APLICACION: CHEVROLET,CORSA, PALIO , SUZUKI

AV - 710

PRV: 493815



APLICACION: FIESTA MOTOR ROCAM, CON PUENTE.

AV - 711

PRV: 593408



APLICACION: KANGOO 1.6, MEGANE
CON MOTOR K4M. TRIDIODO.

AV - 712

PRV: 493832



APLICACION: PEUGEOT,CITROEN.

AV - 713

PRV: 511479



APLICACION: ETIOS

KIT VAL750

RNV:12192
PRV: 511479



APLICACION: ETIOS

RB 145220



APLICACIONES: Fiat Palio, Siena, Bravo. Marea; Alfa Romeo

RB 145231

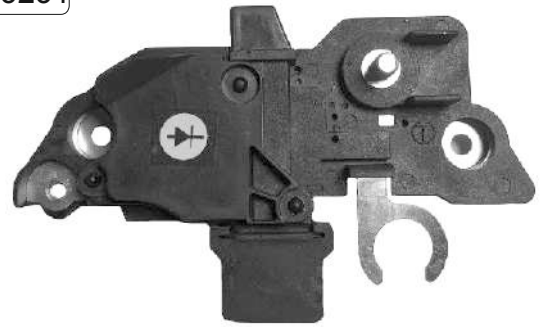

APLICACIONES: Chevrolet ,Agile, Aveo

RB 145235

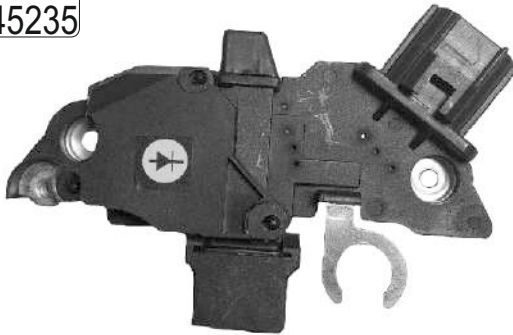

APLICACIONES: Ford Courier, Ka, Fiesta, Ecosport

RB 145225

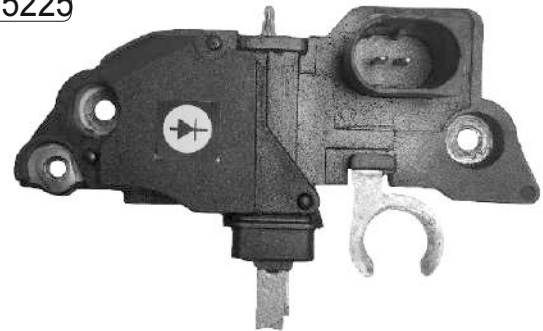

APLICACIONES: Audi A3; Seat Toledo; VW Bora, Golf 4, New Beetle

RB 145236

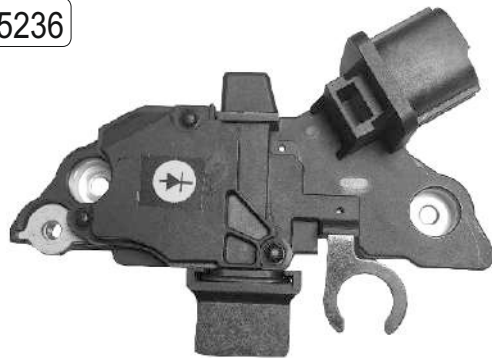

APLICACIONES: Toyota Corola 1.6/1.8, Hilux 07

RB 145239



APLICACIONES: Renault Kangoo, Clio I y II, Megane, Laguna y Scenic

RB 145256



APLICACIONES: M. Benz; VW Camiones y Ómnibus

RB 145243



APLICACIONES: Alfa Romeo; CitroEN; Fiat; Lancia; Peugeot



RB 145229



APLICACIONES: Volv; Audi; M.Benz; VW Bora; Golf, New Beetle, Passat.

RB 220701



APLICACIONES: VW, Gol, Up, Fox.

RB 346011



APLICACIONES: Citroen, Peugeot, Renault.

RB 346021



APLICACIONES: MB

RB 220703



APLICACIÓN: Fiat Palio, Fiat Siena, Fiat Strada, Fiat Uno 2009;2011,Ford Ranger

RB 220706



APLICACIÓN: Renault: Clio, Sandero, Logan, Kangoo, Duster 1.6

RB 346139



APLICACIONES: Audi A6, Q7; VW CC, PASSA T

RB 346066



APLICACIONES: BMW; Mini Cooper;Peugeot 207,308; Citroen Berlingo, C5,DS3

RB 066

REEMP: ROTOF.U346066 14V



APLICACION:MW.Mini Cooper,Peugeot 207,308

RB 034

REEMP. ROTOF: U034 14V



APLICACION:M.Benz

RB 040

REEMP: ROTOF.U040 14V



APLICACION:Chevrolet.Corsa

RB 7001

REEMP: RTOOF.U457001 28V



APLICACION:Bosch/Wapsa

RB 1523

14V



APLICACION:Ford Fiesta 1.0.1.3,KA

RB 1214

14,5V



APLICACIONES:Audi,BMW,Volvo,GM Corsa,Omega.

RB 1239

14,5V



APLICACIONES:Volvo,VW

RB 1240

14,1V



APLICACION: 1995 Peugeot 806TD, Partner Diesel



RB 016/034 Regulador Curvo

14V



APLICACION: M. Beenz, MWM, Camion Agrale

RB 010/027

14V



APLICACION: Fiat UNO, 147, Fiorino, GM 1.6, 1.8 Y 2.0, Ford 1.8

RB 014/018 Regulador Curvo

28V



APLICACION: Volvo, M. Beenz, Scania

RB 053

28V



APLICACION: Volvo, M. Beenz, Scania

RB 1030

14V



APLICACION: Audi; J. Deere; M Beenz; GMC Camiones; Volvo

RB 1090

14V



APLICACION: VW; Fiat; BMW; Alfa Romeo; Audi; Porsche

RB 1022

14V



APLICACION: M. Beenz, Furgon y Pick UP 180D

RB 1301

24V



APLICACION: M. Beenz, Scania



RDR 582947 REEMP. NOSSO: RND 582947 ROTO F:U582947



APLICACION: Chevrolet Cruze 2012, 910 Flex, Diesel 2012, Tracker 2013, Trailblazer 2014

RDR 579662 REEMP. NOSSO: RND 751297 ROTO F: U579662



APLICACIONES: Chevrolet Cobalt, Cruze, Onix, Spin.

RDR9701 REEMP. NOSSO: RND 009701. REEMP. ROTO F: U9701



APLICACIONES: CORSA, OMEGA, VECTRA.

RDR392759 REEMP. NOSSO: RND 392759. REEMP. ROTO F: U392759



APLICACIONES: CHEVROLET, ISUZU

RDR271910 REEMP. NOSSO: RND 271910. REEMP. ROTO F: U271910



APLICACIONES: CHEVROLET SPARK

RDR500187 REEMP. NOSSO: RND 500187. REEMP. ROTO F: U500187



APLICACIONES: CHEVROLET, OPEL

RDR740756 REEMP. NOSSO: RND 740756. REEMP. ROTO F: U740756



APLICACIONES: CHEVROLET

RDR6432 REEMP. NOSSO: REEMP. ROTO F: U6432



APLICACIONES: DAEWOO, SUZUKI, GM

RI-1400



APLICACIONES: Renault 11,18, Fuego motor 2000 C/ AA.

RI-1610



APLICACIONES: Fiat Regatta, Luna, Uno.

RI-1690



APLICACIONES: Renault 9/11/18

RI-1605



APLICACIONES: Perkins print Fiat Diesel-Ford Sierra, Escort

RI-1645



APLICACIONES: MB 1112, 1114, 1517, 1521, 1526/Scania Camiones C/SALIDA P/TAQUIMETRO, Sus maquina vial y agricola.

RI-1640



APLICACIONES: Scania M.BENZ Deutz 28V

RI-1540



APLICACIONES:

RI-1725



APLICACIONES: M.BENZ 12V 90A

RT-100



REGULADOR UNIVERSAL EXTERNO REGULABLE 12V

RT-101



APLICACION: 24V Reguladores externos

RT-105



APLICACION: Fiat, Renault, GM, Ford Peugeot, Universal 12V

RI-1680



APLICACION: 24V, Fiat extractor Maquinrias varias.

RI-1425



APLICACION: 24V Fiat extractor, varios

RI-1248



APLICACION: 12V MB Motor OM352

RI-1720



APLICACIONES: 12V Fiat, GM, MB, Universal.

RI-1945



APLICACIONES: 12V Ford Ranger, GM, MB Maxion

RI-1177



APLICACIONES: 12V VW GOL, Polo, ETC

RI-1179



APLICACIONES: VW GOL III, Saveiro Polo

RI-1444



APLICACIONES: Ford Ranger Nafta 2,3

RI-1213



APLICACIONES: 12V Deutz, GM, VW GOL II S/AA

SL-9009



APLICACIONES: 12V DPS/DPA

SL-240



APLICACIONES: 12V CAV/BOSCH

SL-7180



APLICACIONES: 24V DCP/DPA

SL-1016



APLICACIONES: 24V CAV 7240/BOSCH

RM 361 REEMP. NOSSO: RNM611361 ROTO F: U5300



APLICACIONES: Fiat Siena, Palio Ducato

RM 20056 REEMP. NOSSO: Rm209305 ROTO F: U20056.



APLICACIONES: Fiat Punto, Ford, Land Rover

RM 601010 REEMP. NOSSO: RNM 56241. ROTO F: U601010



APLICACIONES: Ford Focus 1.4 y 1.6

URTT118 REEMP. NOSSO: RM118C. ROTO F: URTT118



APLICACIONES: Renault

URTT19A



APLICACIONES: Fiat

URTT119B

24V



APLICACIONES: Fiat

RMM 114 REEMP. ROTO F: URTT114A



APLICACIONES: Fiat; Lancia; Nissan; Seat

RMM 1718 REEMP. ROTO F: U61718



APLICACIONES: Ford, Land Rover, Mazda



RMT-25572



APLICACION: L-200 Fuso,Eclipse

RMT-49872



APLICACION:Peugeot 206,307,308

Anclaje con Rectificador:51
Diámetro Portaescobilla: 24,5
Salida: Renault

RMT-23200



APLICACION:Ford Escort,Fiesta,Orion,Zeta,Peugeot.

Diámetro Portaescobilla:24,5
Anclaje con Rectificador:51

RMT-1070



APLICACION: Mazda Capella,Mitsubishi,Pajero(diesel)

RMT-29570



APLICACION:Honda

Diámetro Portaescobilla:24,5
Anclaje con Rectificador:51
Salida:4 Pines

RMT-00958

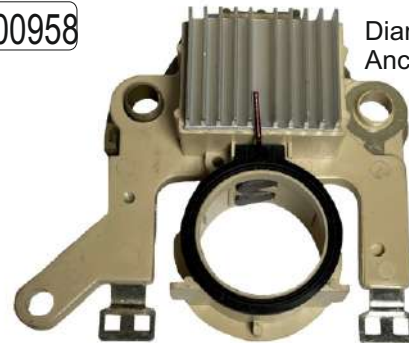

APLICACION:Citroen Berlingo

Diámetro: 24,5
Anclaje con Rectificador: 51

RMT-7203J



APLICACION:Honda Clvic

Diámetro Portaescobilla:24,5
Anclaje con Rectificador:51
Salida: 4 Pines

RMT-40371



APLICACION:Ford Transit 2.5 Diesel

Diámetro Portaescobilla:36
Anclaje Rectificador:52
Salida tipo VW

RN 0610

3 Pines



APLICACION:Toyota Corolla, 4 Runner,RAV4

RN 1750

3 Pines



APLICACION:Toyota

RN 003430

3 Pines



APLICACION:Ford, Land Rover, Lincoln, Mazda
Mercuri, Volvo

RN 003020

4 Pines



APLICACION:Toyota RAV4, Lexus

RN 03350

4 Pines

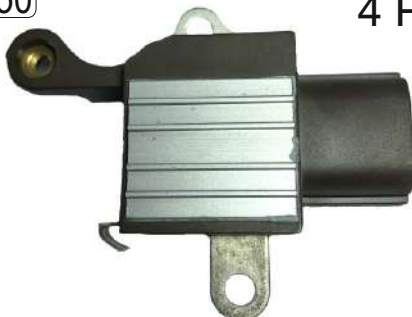

APLICACIONES:Acura, Honda Accord,
Honda CRV 14V.

RN 00022

3 Pines



APLICACION:Lexus, Toyota 14V

RN 1580

3 Pines



APLICACION:Toyota, Chevrolet

RN 0150

4 Pines



APLICACION:Toyota Hilux desde 2005

RN-0570

4 Pines

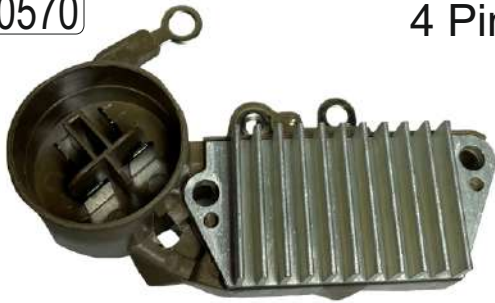

APLICACION: Honda, Accura

RN-0931

3 Pines



APLICACION: Toyota, John Deere

RN-0340

3 Pines



RN-1200

3 Pines



APLICACION: Isuzu

RN-0180



APLICACION: Toyota, Hino

RN-1810

3 Pines



APLICACION: Mazda, Toyota

RN-003240

2 Pines



APLICACION: Buick; Chevrolet Cruze II 1,4 2017

RN-03010

4 Pines



APLICACION: Ford Focus TDCi, Lexus, Ponitac, Scion, Toyota 14V



RV 857

REEMP. NOSSO RNV593857 ROTOF. U93857

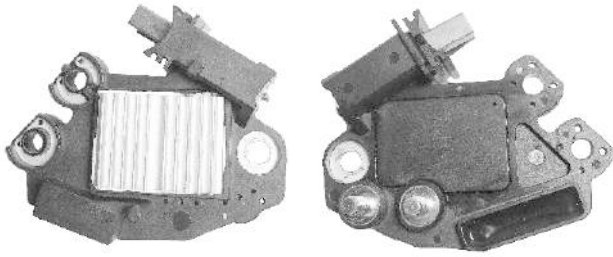

APLICACIONES: XSARA PICASSO 206,307.

RV 455

REEMP. NOSSO RNV593455 ROTOF. U93455

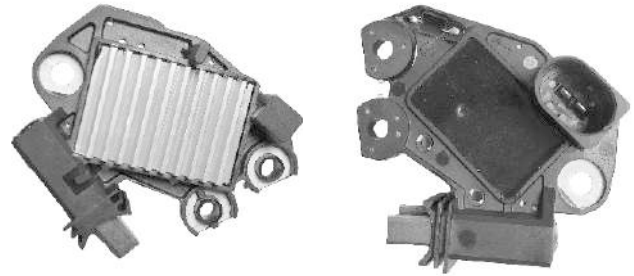

APLICACIÓN: AUDI, VW.

RV 529

REEMP. NOSSO RNV593529 ROTOF. U93529

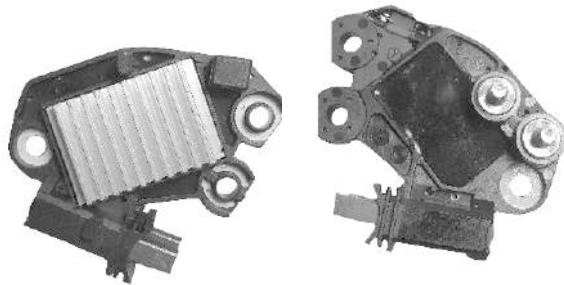

APLICACIÓN: CITROEN XSARA PICASSO, PEUGEOT 206,307.

RV 316

REEMP. NOSSO RNV593316 ROTOF. U41952

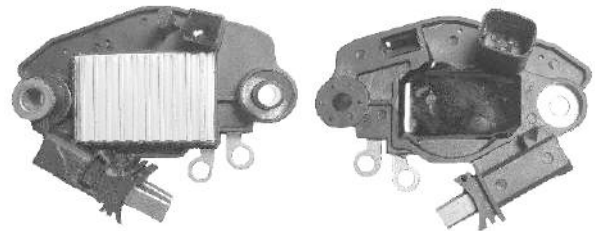

APLICACIÓN: CLIO 2, SPACE, KANGOO.

RV 932

REEMP. NOSSO RNV590932 ROTOF. U41715

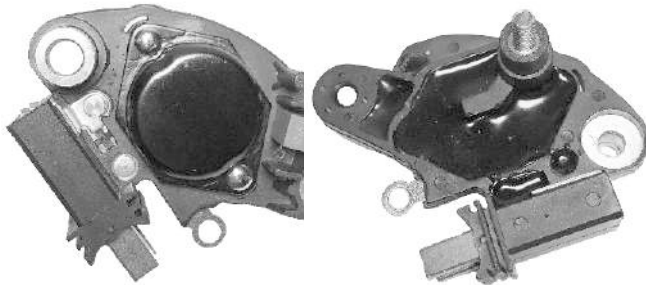

APLICACIÓN: FIAT.

RV 505

REEMP. NOSSO RNV593505 ROTOF. U593505

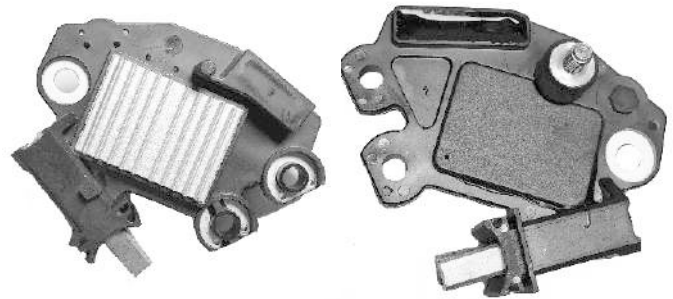

APLICACIÓN: CHEVROLET, FIAT, FORD.

RV 299

REEMP. NOSSO RNV542299 ROTOF. U42270

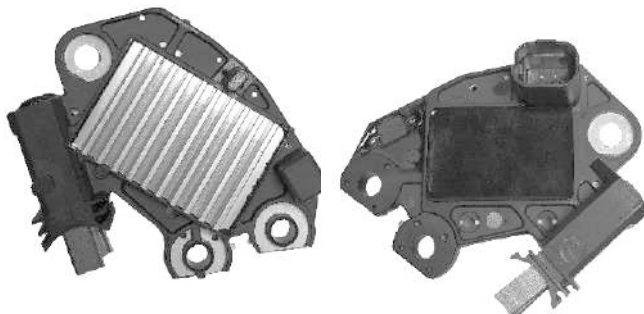

APLICACIÓN: RENAULT CLIO, LAGUNA, SANDERO, LOGAN

RV 791

REEMP. NOSSO RNV592791 ROTOF. U1335

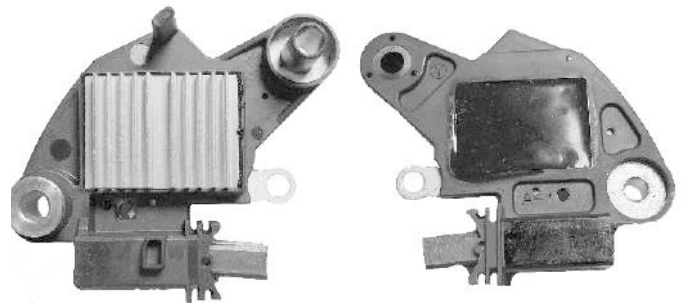

APLICACIÓN: CHEVROLET, AUDI, PEUGEOT, VOLKSWAGEN.

RV 532

Reemp. NOSSO: RNV593532. Reemp. ROTOF: U543494

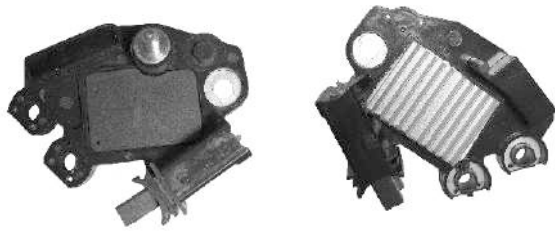

APLICACION: Peugeot, Citroen

RV 675

Reemp. NOSSO: RNV593675. Reemp. ROTOF: U593675

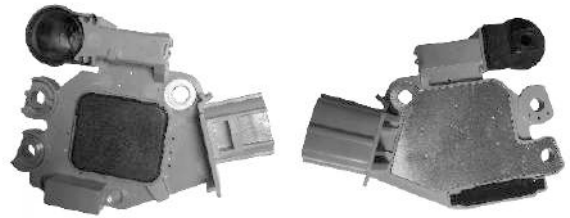

APLICACION: Ford, Fiesta, KA MAX

RV 765

Reemp. NOSSO: RNV54765. Reemp. ROTOF: U42765

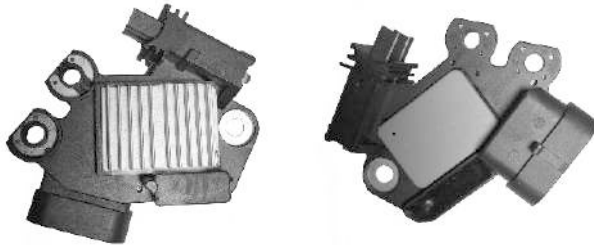

APLICACION: Ford, Fiesta, Scord, GM

RV 802

Reemp. NOSSO: RNV592802. Reemp. ROTOF: U592802

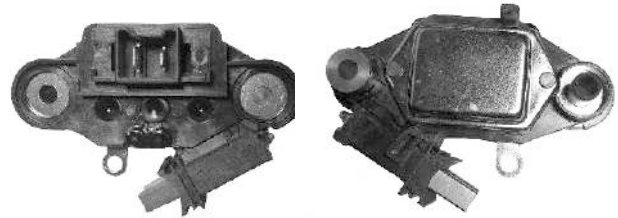

APLICACION: Renault, Audi, VW

RV 290

Reemp. NOSSO: RNV593290. Reemp. ROTOF: U93290

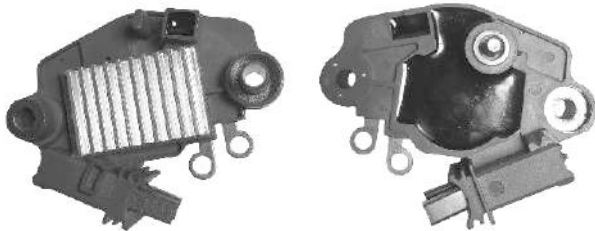

APLICACION: Renault Clio 2, Senic, Megane

RV 406

Reemp. NOSSO: RNV592793. Reemp. ROTOF: U41406

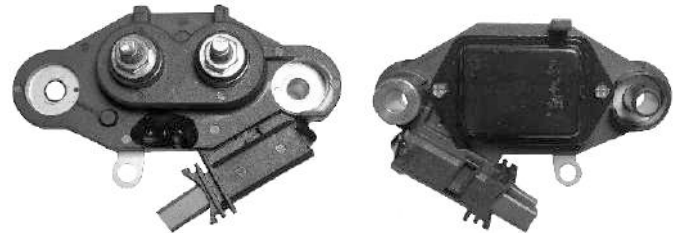

APLICACION: Paris Rhone, Renault

RV 1925

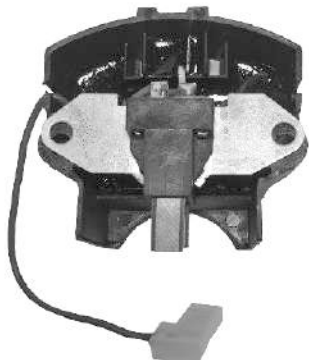

APLICACION: Renault 19, Peugeot, Citroen.

RV 1652



APLICACION: Renault 18, 19, 21, Clio.